

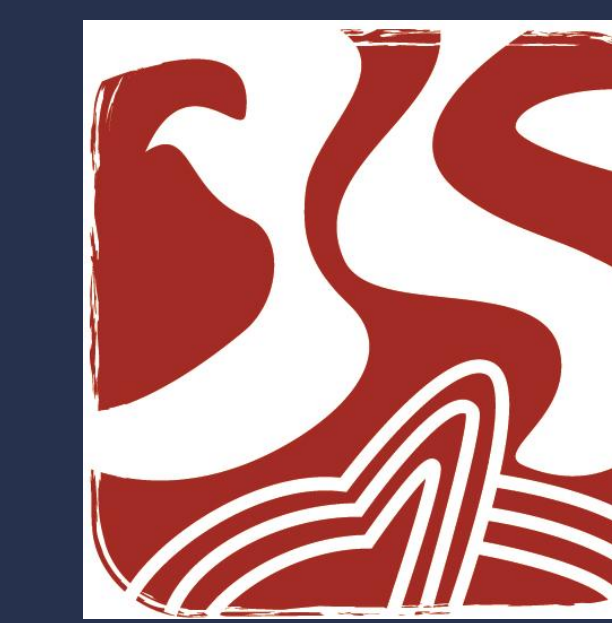

Wishing Well Coin Cleaning

Team 013 - Deep Sea Nautilus



Guangdong Experimental High School, Guangdong Overseas Chinese High School & Beijing No. 35 High School, China

Abstract

Tourists often toss coins into pool of tourist attractions for good luck, this behavior contaminated the pool and add cleanup challenges for management. We design a ROV to remove coins from pools.

The ROV is constructed from PVC pipes and has four thrusters: two for vertical movement and two for horizontal movement. The coin-picking device consists of two tracks fitted with magnets to pick up coins. The tracks are driven by a motor, and can transport coins from the bottom to the upper section, where they are scraped into a collection basket. So the tracks can pickup coins continuously. During the design and fabrication process, we conducted iterative testing and improvements. Results confirm that the machine is capable of collecting coins from the bottom of water features.

Background & Motivation

At many tourist attractions both in China and abroad, visitors often toss coins into wishing will, believing this act will bring good luck. Although many site management authorities post “No Littering” signs, these have had little effect. For example, Baotu Spring in China, the Trevi Fountain in Italy, and a local pub in Sussex, England, have all been plagued by this behavior. However, this practice has negative consequences for both the aquatic environment and site management.



Fig 1, 2



Fig 3

Negative Effects of Coin Tossing:

(1) **Water pollution** When coins are submerged in water for extended periods, tiny metal particles dissolve into the water. Over time, the coins rust, causing water pollution that affects aquatic life;

(2) **Difficulty of cleanup** Coins are small, and when their numbers accumulate, they become difficult to remove from the water, posing a challenge for site management. To address this issue, we plan to design an ROV to retrieve coins from the water.



figure 4

Methodology

To remove coins from the pool, we designed an ROV and developed a specialized **coin-picking device** for it. The design iteration process is as follows.

Initial version

A magnet mounted on the underside of the ROV is used to attract the coins.

Detailed description:

(1) **The ROV's structure:** built from PVC pipes. It uses **four thrusters**: two control vertical movement, and the other two control forward motion and steering.

(2) **coin-picking device:** A plastic mesh (160 mm× 240 mm) is mounted on the bottom of the ROV (Fig 6), **with magnets secured to it**. Every magnet is 40mm×20mm×3mm (Fig 5).

(3) **How it works?** When submerged, the ROV moves toward the location of the coins, directly picks them up, and brings them to the surface.



Fig 5

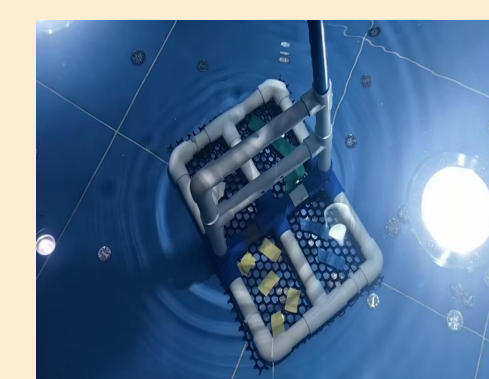

Fig 6

Advantages	Disadvantages
Simple structure and operating principle; easy to build.	the system can only pick up coins once

Improved Version

We design a **transmission system** consisting of a track and gears. Magnets are attached to the track; the rotating track collects coins, and a collection device is designed to retrieve them.

Detailed Description:

(1)**The ROV's structure** The overall **frame** of the ROV adopts a structure that is higher at the rear and lower at the front (Fig 7), facilitating the installation of the track. two vertical thrusters are installed in the middle; and two horizontal thrusters are installed at the rear.

(2) **Coin-picking device**

a.Track Structure — we use four LEGO bricks to form gears that work in conjunction with two tracks.

b.Magnets – we chose the 30mm*10mm*3mm magnets which is matching the length and width of the tracks. They are attached to the tracks using **nano double-sided tape** (Fig 8).

c.Power Transmission—A DC motor is the power source whose shaft is connected via a coupling to the gear shaft on the track, driving the gears.

d.Coin Collection Device — A collection basket is located at the rear of the ROV, and two scrapers are designed on the frame to dislodge coins from the magnets into the collection basket.

(3) **How it works?**

When the ROV near the coins, start the DC motor, then the LEGO gears rotate and the two tracks move. And the coins which are picked up by magnets move until the scrapers dislodge them.

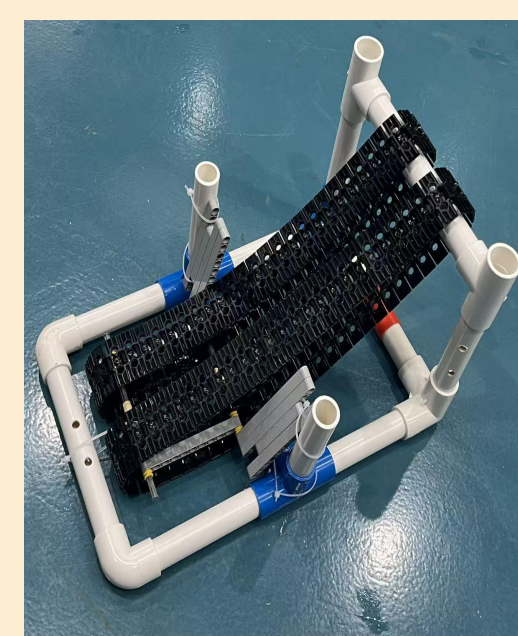

Fig 7



Fig 8

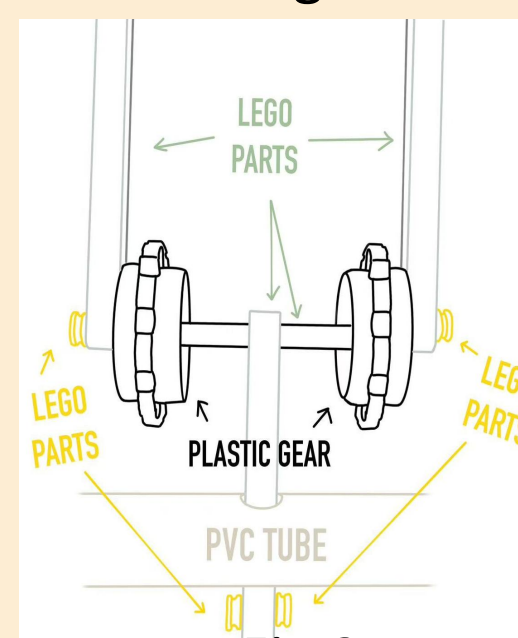

Fig 9

Advantages	Disadvantages
The track with magnets can repeatedly pick up coins, improving the efficiency.	When the tracks move, the structure is loose and unstable.

Final Version

Improving structural stability by repositioning the gears.

(1) **Gear Installation:** We modified the gear structure by embedding the gear shaft into a tube and relocating the two bottom gears to the top. This simplifies the machine's bottom structure, prevents parts from interfering with one another, and improves stability.

(2) **Motor Installation:** We also used **3D-printed parts** (Fig 11) to securely mount the motor.

(3) **Reduction gears:** We use Lego 40-tooth gear and 24-tooth gear to reduce motor speed (Fig 12).

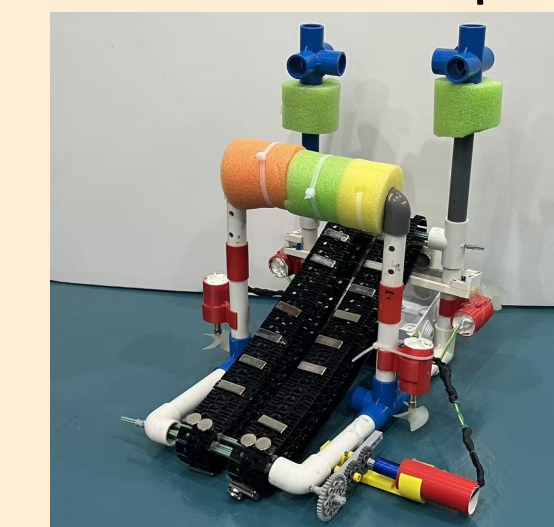

Fig 10

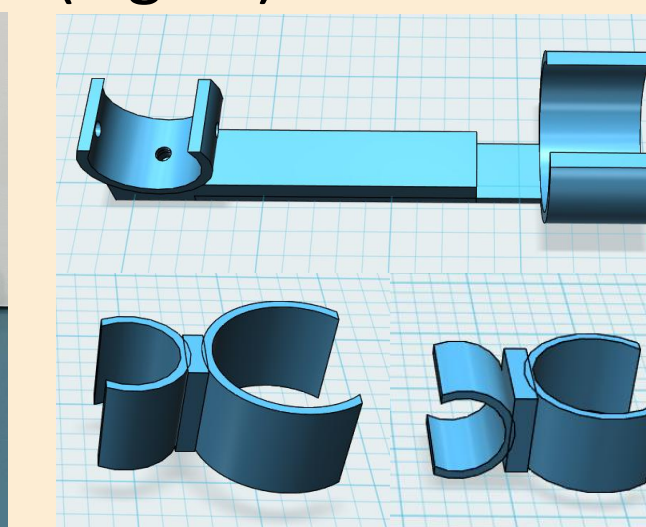

Fig 11



Fig 12

Results & Discussion

After completing the overall design of the machine, we conducted the following tests and analyse.

Circuit Diagram

The ROV is battery-powered, the battery voltage is 12V. There are five motor connected in parallel in the circuit.

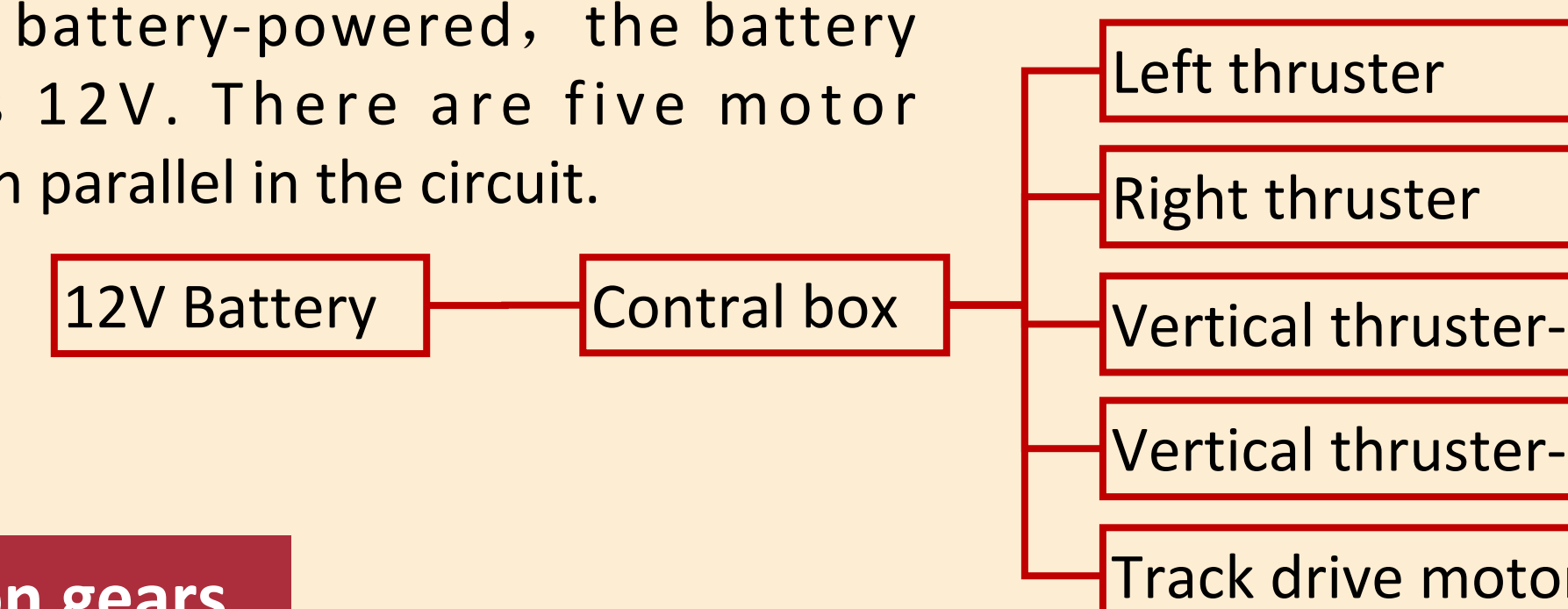

Reduction gears

For the transmission system, we designed a continuous drive using multiple interconnected gears and incorporated a driven gear with a higher number of teeth to reduce speed. This ensures normal operation while slowing down the entire system, thereby preventing structural damage caused by excessive rotational speed.

The rotational speed of the DC motor: **281 r/min**
 The first and the second gear: 24-tooth, the third gear: 40-tooth
 The rotational speed of the last gear shaft: **168r/min**(281*24/40)
 The angular velocity of the last gear shaft:

$$168r/min = 2\pi * 168/60 \text{ rad/s} = 5.6 \pi \text{ rad/s}$$

The diameter of the track gear:**41mm**

The speed of the track: $5.6\pi \text{ rad/s} * 41mm/2 \approx 0.36m/s$

ROV test

Taking a Chinese coin as an example, we measured its various data and tested our machine. As shown in the test data below, the ROV's collection efficiency is acceptable, and it demonstrates some adsorption capability.

	One magnet	One track	Coin value
One-yuan coin	6	23	23yuan
Five-jiao coin	9	17	8.5yuan
One-jiao coin	14	76	7.6yuan

	Diameter/cm	Area/cm ²	Quality/g	Volume/cm ³
One-yuan coin	2.25	5.1	6.1	0.91
Five-jiao coin	2.05	4.2	3.8	0.54
One-jiao coin	1.90	3.6	3.2	0.50

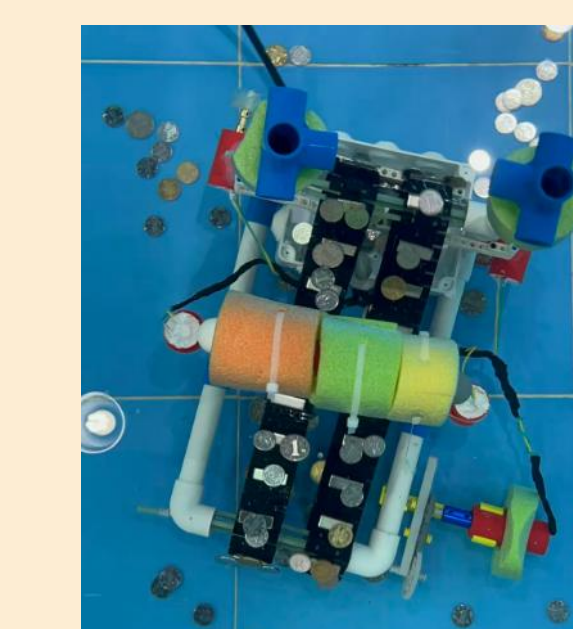

Fig 13

Conclusion

We planned to design an ROV capable of retrieving coins from water, and ultimately completed both the design and construction. Preliminary tests conducted at our school demonstrated that **this project has the potential for real-world application:**

- (1) The ROV can move up and down, left and right, and forward and backward in the water.
- (2) The DC motor drives the tracks, and after being reduced by a gear reducer, the tracks move steadily at a slow speed.
- (3) The magnets on the track can pick up coins continuously.
- (4) The scrapers can remove most of the coins from the magnets, and the collection box collects the coins.

However, to adapt to the complex and ever-changing real-world environment, our ROV still requires further refinement and optimization. Through this project, the multiple iterations of the ROV not only enhanced our logical **thinking, creativity, and patience but also strengthened our teamwork skills**. We intend to continue refining the details and improving the machine, and we plan to engage with scenic areas to explore the feasibility of deploying this ROV on a small scale to assist them.

Next Steps

1. The ROV is only suitable for flat surfaces; we will continue to refine its dimensions and structure to adapt to **different pool environments**.
2. Choose magnets with lower magnetic strength, **improve the design of the scraper and collection box** to capture more coins, improve collection efficiency.
3. Install a waterproof night-vision **camera and a spotlight** on the front of the ROV to facilitate control and monitoring by shore-based operators.
4. Deploy an **intelligent programming system** to enable the device to autonomously perform tasks in specific scenarios.
5. Design a **coin sorter** for on-site sorting of recovered coins.

Acknowledgements

We would like to thank the SeaPerch International Challenge Organizing Committee for providing us with a platform to interact with young people from around the world and gain new knowledge. We also thank our school for introducing us to the SeaPerch challenge, sparking our interest, and providing us with materials and guidance. We would like to thank our science and technology teachers—Zhang Yucheng, Wu Defen, Yin Ying, and Zhang Boya—for their quiet dedication and support behind the scenes; we thank all the family members, teachers, and classmates who supported us and offered their help; and we also thank every member of our team for their hard work and perseverance.